



Wireless Door Chime Model RC516

PRODUCT FEATURES

- Adjustable volume control.
- Channels are selectable to allow more than one door chime set in same building.
- Sounds different tunes for front, second, and third doors.
- Accessory buttons available for second and third doors.

QUICK START

1. Insert battery into button.
2. Insert (4) "C" batteries (sold separately) into chime receiver.
3. Place Chime where you would like it.
4. Hold button where you would like to mount it. Push button and if chime works, mount button. If not, read details that follow.

INSTALLATION

Regulatory Information

The user is cautioned that changes or modifications not expressly approved by the party responsible for regulatory compliance could void the user's authority to operate this equipment.

1. Open the chime button case by inserting a flat blade screwdriver into the notch on the bottom and push to open. Lift the front of the button up and away from the back.
2. Insert the A23 battery into the button. The + side of the battery goes up.
3. Insert (4) "C" batteries into chime receiver. Test operation by pressing button.

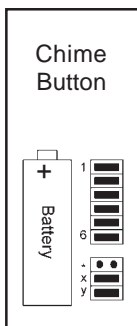

If chime doesn't operate, see troubleshooting section.

Before mounting the button, hold it where you wish it to be and test the operation. If it works, mount it there. If it doesn't work, see the troubleshooting section. If mounting to a metallic or concrete surface, use a 1/8" to 1/4" wood spacer between the back of the button and the surface to increase the range.

Wireless chime range can vary from 20 to 125 feet depending on the construction of the building. Wood or vinyl siding are ideal. Steel, aluminum, brick or stucco decrease the range.

- Set each button to ring a different tune for each door. Change door set jumpers on the button.

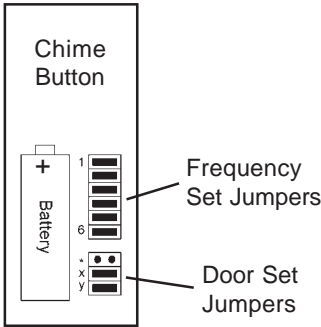

- Set the chime volume by gently turning the volume control with a small screwdriver.
- Mount the button by using the two holes in the back of the case. Mount so the long hook is on the bottom. **If mounting to a metallic or concrete surface, use 1/8" to 1/4" wood spacers between the back of the button and the surface to increase range.** Snap the button on the back case.

OPERATION

Press the door chime button to verify that the button and chime work properly. When the button is pressed, the chime should sound. If it doesn't, check that the frequency codes are set the same and that the alkaline batteries are fresh.

Door Set Jumpers

* □ □



Put jumpers on pins X and Y for Westminster chime.



X □ □

Put jumpers on pins * and Y for 2-note "ding-dong".



X □ □

Put jumpers on pins * and X for 1-note "ding".

Y □ □

BUTTON BATTERY REPLACEMENT

Open button case (see step #1). Replace with one 12 volt alkaline type A23 (Broan Model RCA23) or MN21 battery. Close button case.

FREQUENCY CODES

If you are adding a second chime receiver to another area of the same residence, make sure the frequency codes on the additional receivers are set the same, so will all ring when a button is pushed.

The first six pins on the chime and button change the frequency code. Remove the exact same one or two pins from the chime and button. After making your changes make sure the jumpers on the first 6 pins match on both the chime and button.

If your chime goes off by itself, it may be experiencing interference from a neighbor's wireless chime. You can stop this from happening by changing the frequency code of your chime.

ADDITIONAL DOOR CHIMES

When installing other wireless Door Chime sets, remember to set frequency codes to different settings to avoid interference. If you want them to all ring at the same time, set them to the same frequency code.

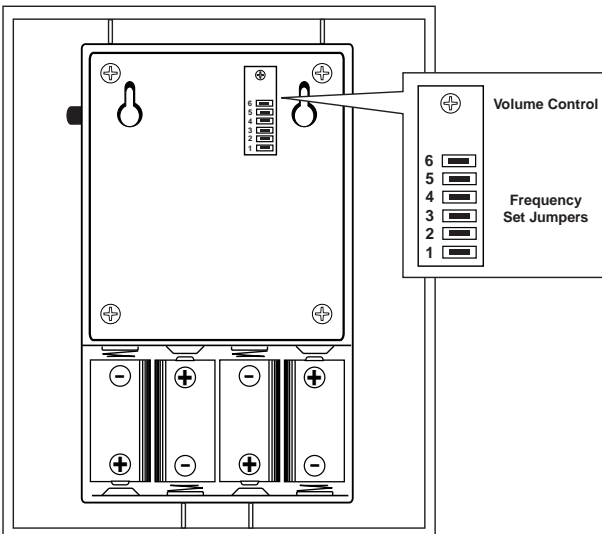
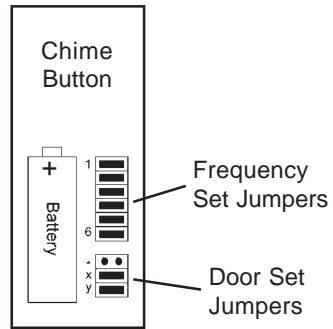

Back View

TROUBLESHOOTING

The range of the door chime depends on location, temperature and battery condition. If you are having problems with this product, please try the solutions listed below.

Chime rings on its own:

- A neighbor may have a wireless chime set with the same frequency jumper settings. Change the chime and button frequency jumpers.

Chime doesn't sound:

- Make sure the button and the chime jumpers are set the same.
- Replace the button battery. Also check chime batteries.

Batteries are OK, but chime does not work when installed:

- Mounting the chime or button directly on metal, concrete or near metal studs reduces the range. Use 1/4" to 1/2" wood shims to move the chime or doorbell button off of the surface.
- Do not mount the chime too close to ground level concrete slabs, which may reduce the range. Mount the chime away from the floor.
- Try different locations for the chime closer to the button. Also, try to orient the chime at a different angle to increase the range. Range is most effective to the sides of the button.

Questions on this product?

Call 1-800-637-1453 7:30 AM to 6:00 PM Central Time, Weekdays

WARRANTY

BROAN-NUTONE ONE YEAR LIMITED WARRANTY

Broan-NuTone warrants to the original consumer purchaser of its products that such products will be free from defects in materials or workmanship for a period of one year from date of original purchase. THERE ARE NO OTHER WARRANTIES, EXPRESSED OR IMPLIED, INCLUDING, BUT NOT LIMITED TO, IMPLIED WARRANTIES OR MERCHANTABILITY OR FITNESS FOR A PARTICULAR PURPOSE.

During this one-year period, Broan-NuTone will, at its option, repair or replace, without charge, any product or part which is found to be defective under normal use and service. THIS WARRANTY DOES NOT EXTEND TO FLUORESCENT LAMP STARTERS AND TUBES. This warranty does not cover (a) normal maintenance and service or (b) any products or parts which have been subject to misuse, negligence, accident, improper maintenance or repair (other than by Broan-NuTone), faulty installation or installation contrary to recommended installation instructions.

The duration of any implied warranty is limited to the one-year period as specified for the express warranty. Some states do not allow limitation on how long an implied warranty lasts, so the above limitation may not apply to you.

BROAN-NUTONE'S OBLIGATION TO REPAIR OR REPLACE, AT BROAN-NUTONE'S OPTION, SHALL BE THE PURCHASER'S SOLE AND EXCLUSIVE REMEDY UNDER THIS WARRANTY. Broan-NuTone SHALL NOT BE LIABLE FOR INCIDENTAL, CONSEQUENTIAL OR SPECIAL DAMAGES ARISING OUT OF OR IN CONNECTION WITH PRODUCT USE OR PERFORMANCE. Some states do not allow the exclusion or limitation of incidental or consequential damages, so the above limitations or exclusion may not apply to you.

This warranty gives you specific legal rights, and you may also have other rights, which vary from state to state. This warranty supersedes all prior warranties.

To qualify for warranty service, you must (a) notify Broan-NuTone at the address stated below or telephone 1-800-637-1453, (b) give the model number and part identification and (c) Describe the nature of any defect in the product or part. At the time of requesting warranty service, you must present evidence of the original purchase date.

Broan-NuTone LLC, 926 West State Street, Hartford, WI 53027

99524935A